

# ACCUTIRE®

MS-4034

## MULTI FUNCTION EMERGENCY FLASHER & TIRE GAUGE

### User Manual



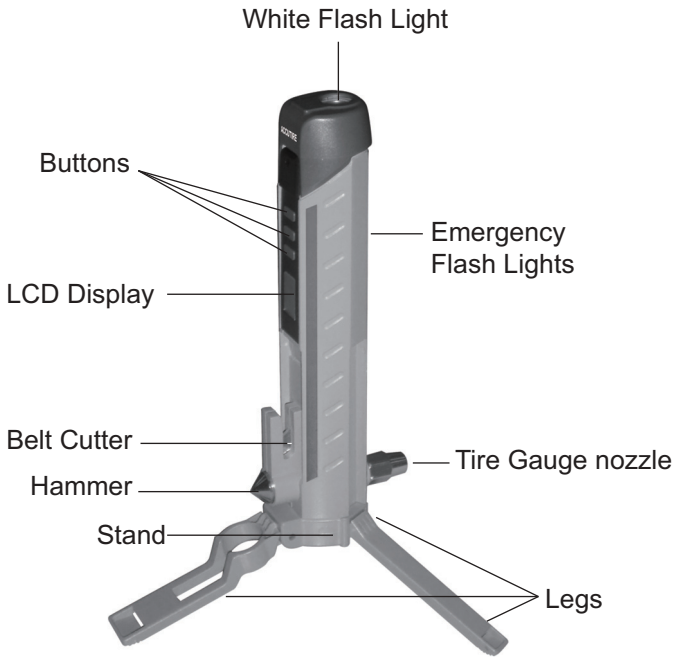

## LCD Layout and Buttons



### Gauge has 3 Buttons



used to start gauge and set up measurement units



used to turn on white flash light



used to turn on and change mode of emergency light

## Specifications

Tire Pressure Range.....	5~150 psi / 0.4~10.30 bar / 35 kPa~1030 kPa / 0.4~10.30 kg/cm <sup>2</sup>
Tire Pressure Resolution.....	0.5 psi / 0.05 bar / 5 kPa / 0.05 kg/cm <sup>2</sup>
Accuracy.....	+/- (1% + 1 LSD)

## Gauge Operation Instructions

Set up measurement units

- 1 Start gauge by pressing ON button 
2. Gauge will show all segments and after that 0.0 psi on display.



3. Press  repeatedly to scroll through units.
4. Gauge is ready for operation.
5. Gauge will automatically shut off in 10 seconds.

## Pressure Measurement

1. Press ON button  or push nozzle of gauge directly on to tire valve, gauge will show all segment and after that 0.0 psi on display.



2. Hold gauge on tire valve stem, the display will first flash a full screen, and then until the actual pressure reading is displayed and locked.
3. Promptly remove gauge from valve stem.
4. The pressure reading will show (stay) on the LCD for about 10 seconds.
5. Gauge will reset to 0.0 or 0.00 or 0 after 10 sec.
6. Gauge will turn off after 10 sec interval from gauge displays 0.0 or 0.00 or 0

## **Error Messages**

To replace the batteries:

1. LCD will display "Lo" warning when battery power is lower than 2.9V +/- 0.2V
2. Remove the battery cover.
3. Remove the old batteries and replace with new batteries. Do not mix old and new batteries.
4. Replace battery cover back.

Over range:

When tire gauge is over range at 153psi / 10.60bar / 1060kPa / 10.60kg/cm<sup>2</sup> the display will show "E"

## **Emergency /Flare tool stand**

1. Unfold 3 legs, pull the stand away from the gauge (picture 1-1, 1-2, 1-3)
2. Turn the stand upside down (picture2-1) and push the stand back to the gauge (picture2-2), (Note: the slot in stand indicate the right direction matching with gauge). Then the gauge can stand firmly on the flat ground.



1-1



1-2

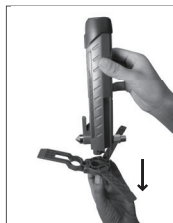

1-3

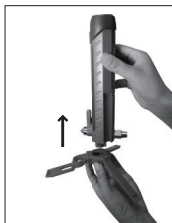

2-1





2-2

## Flash Lights

White flash light

1. To turn on the flash light, press and hold the  flash light button.
2. To turn off the flash light, release the light button.

## Emergency lights

1. To turn on Emergency lights press and release  button.
2. To change Emergency light modes press  button repeatedly.
3. There are 5 different flash modes:
  - a) All lights ON
  - b) Flash light fast
  - c) Flash light slow
  - d) Running flash lights
  - e) Alternatively half lights flash

**Note:** To ensure the emergency light works well, you need to stand the tripod tool when you use the flash light in emergency.

## Install Batteries:

1. Remove the battery door by pressing and sliding (Picture 1).
2. Install 3x AA batteries in proper orientation and correct +/-polarity (Picture 2&3).
3. Replace the battery door as picture (Picture 4).
4. Note do not mix old and new batteries.

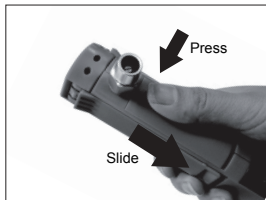

1



2

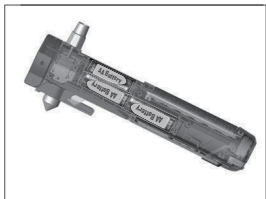

3

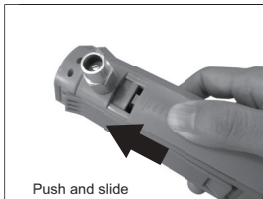

4

## Care and Maintenance

To clean the gauge, use a soft, damp cloth. Do not immerse or spray water or other liquid cleaners on the gauge.

## Warranty and Service

Measurement Ltd., Inc. warrants this product against defects in material or workmanship for a period of five (5) year from the date of purchase and agrees to replace it. This warranty does not cover damage resulting from misuse or abuse of the product. Should your product require service, you may send it back to Measurement Ltd., Inc. for repair or replacement.

## FCC Information

This equipment has been tested and found to comply with the limits for a Class B Digital Device, pursuant to Part 15 of the FCC Rules. These limits are designed to provide reasonable protection against harmful interference in a residential installation. This equipment generates, uses, and can radiate radio frequency energy and, if not installed and used in accordance with the instructions, may cause harmful interference to radio communications. However, there is no guarantee that interference will not occur in a particular installation.



If this equipment does cause harmful interference to radio or television reception, which can be determined by turning the equipment off and on, the user is encouraged to try to correct the interference by one or more of the following measures:

- Reorient or relocate the receiving antenna.
- Increase the distance between the equipment and receiver.
- Connect the equipment to an outlet on a circuit different from that to which the receiver is connected.
- Consult the dealer or an experienced radio/TV technician for help.

This equipment complies with Part 15 of the FCC Rules. Operation is subject to the following two conditions:

1. This equipment may not cause harmful interference.
2. This equipment must accept any interference received, including interference that may cause undesired operation.

Modifications not authorized by the manufacturer may void the user authority to operate this device.

**U. S. Patent NO.  
D724458; D724,458S**



**Measurement Ltd., Inc.**  
[www.measurement-ltd.com](http://www.measurement-ltd.com)

Our authorized service center address:  
11751 Rock Landing Drive, Suite H-7, Newport News, VA 23606  
Attn: Customer Service  
Tel : 757-706-3839